

PowerMax+ i3048
Pure Sine Wave Inverter
User's Manual

1. Security

IMPORTANT: To prevent bodily injury or property damage, please follow these instructions precisely. With personal safety as a primary focus in design, this charge controller has been engineered to function properly and efficiently.

1. Professional installation and guidance is always recommended. Otherwise, please contact your authorized PowerMax+ agent before installation.
2. Keep the inverter dry. Do not clean with a wet or damp cloth. This is an electric device and cannot get wet at all. Prevent any spills on or near the inverter.
3. Keep all children and any person with limited understanding and/or decreased mental capacity away from the controller.
4. Keep the controller away from direct sunlight or any other heat source.
5. Please check the rated voltages of your wind turbine, solar panel and battery before connection. Their rated voltages all should be the same.
6. Pay close attention to the connection of your wind turbine, solar panels and batteries to make sure positive goes to positive and negative goes to negative.
7. Smaller gauge wires should not be used with higher current equipment.
8. Ensure that all component connections are tight and secure.
9. **DO NOT TOUCH** any bare parts on the controller. The high voltage can cause lethal shock.

2. General Description

This PowerMax+ inverter can convert the batteries' DC voltage to reliable pure sine wave AC voltage for standard household appliances, such as televisions, computers, water pumps and lava lamps. The inverter is designed to provide years of trouble-free operation and includes an automatic safety monitoring circuitry to protect the inverter and your batteries.

3. Main Features

- Pure sine wave output can power any household appliance
- Integrated circuitry uses less wire connection
- Improved system integration through micro-processor technology
- Excellent protection
 - over voltage shutdown
 - under voltage shutdown
 - overload protection
 - short circuit protection
 - overheating protection

4. Connection

1. Selecting a Suitable Location

For safe and optimum performance, install the inverter in a location that is:

- **DRY.** Do not expose the inverter to spills or humidity.
- **COOL.** Operate only in ambient temperatures between 32°F and 104°F. Keep away from direct sunlight, furnaces, heating vents or other heat producing equipment.
- **WELL VENTILATED.** Allow at least 4 inches clearance above and on all sides of the unit for proper cooling and air circulation.
- **SAFE.** Do not install the inverter in a compartment with flammable liquids or explosive vapors.
- **CLEAN.** Keep the inverter clean and free of dust and/or dirt. This is especially important if the inverter is used in an industrial work environment.

2. Power Connection

1. Using 16mm² electrical wiring, connect the battery's positive pole to the positive (+) battery terminal on the inverter and the same for the negative wire. Be sure the polarity is connected properly. Length of these two connecting wires should be no more than 3 feet. Hand-tighten the nuts on each battery terminal until snug. Do not over-tighten.

2. Connect the load to "AC OUTPUT" Load is defined as whatever is connecting to your appliances, so your "house circuitry".

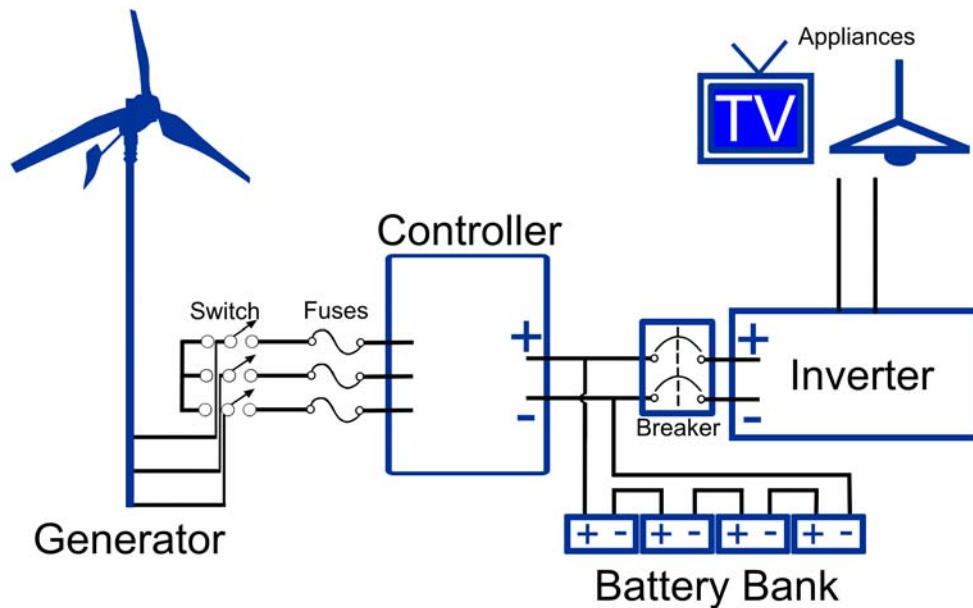

Typical Off-Grid System

5. Operation

Before powering up this unit, please double check to make sure all connections are proper and secure.

1. The IVT switch, when lit with the green LED, indicates the unit is ON and the inverter is supplying pure sine wave power to the AC OUTPUT terminal on the back panel.
2. The inverter is capable of continuously powering AC products that use a maximum of 3kW. Because the power, or 'wattage'. Rating of AC products is the average power they use; the initial starting power may exceed the rated power. Appliances such as TVs, computer monitors and electric motors are examples of products that have high surge requirements at start up. Although your PowerMax+ 3048 inverter can supply momentary surge power twice the power rating, there could be occasions when products rated less than their rated watts may still exceed the inverter's surge capabilities, resulting in a triggered safety overload shutdown. If this problem occurs when attempting to simultaneously operate several AC products, first try switching on the inverter with all AC products (appliances) turned off. After everything is powered off, turn each appliance on one-by-one, starting with the high-surge product first.

6. Troubleshooting

Problem	Possible Cause	Solutions
Inverter shutdown and LCD displays "HIGH BATTERY"	1. Defective batteries or connection 2. Batteries are overcharged	1. Check battery and connection, replace 2. Wait until voltage drops, then inverter will start automatically
Inverter shutdown and LCD displays "LOW BATTERY"	Batteries are fully discharged	Wait until the batteries receive a minimum charge, then inverter will start automatically
Inverter shutdown and LCD displays "OVER TEMP"	Inverter temperature is too high	Inverter will start automatically when internal temperature drops. Make sure that the area is well-ventilated
Inverter shutdown and LCD displays "OVER LOAD"	Power overload	Turn off the inverter and check the load. Turn inverter back on.
Fuse Melted	1. Batteries connected in reverse polarity 2. The inverter has been damaged	1. Re-connect the batteries properly & replace fuse 2. Contact for repair

7. Maintenance

WARNING! DE-ENERGIZE THE SYSTEM BEFORE DOING ANY REPAIR OR MAINTENANCE. THE INVERTER'S CAPACITORS HOLD CHARGE EVEN WHEN THE UNIT IS UNPLUGGED. NO WORK SHOULD BE DONE WITHOUT CONSULTING A LICENSED ELECTRICIAN FIRST!

In order to keep the electric equipment in the best working condition and preserve its performance, we recommend conducting an inspection every 6 months. Again, please take caution in conducting any maintenance or repair.

- Remove dust and dirt from the controller and inverter units.
- Check for any discoloration or deformations of the cable sheaths and components.
- Check to ensure all cables are taut and terminal screws are still tight.
- Check to make sure all module housing screws are tight.

8. Technical Specifications

Model

i3048

Normal Output Power	3KW
Normal DC Input Voltage	48V Dc
Over Voltage Shutdown	68V DC
Over Voltage Recovery	66V DC
Under Voltage Shutdown	42V DC
Under Voltage Recovery	48V DC
No Load Loss	.5A
Output Wave	Pure Sine Wave
Rated Output Voltage	120V AC
Total Harmonic Distortion	<=4%
Output Frequency	60Hz +/- .05Hz
Dynamic Response	5%
Load Capacity	120%, 1min 150% 10S
Inverter Efficiency	90%
Noise Level (1m)	<= 40dB
Isolate Level	1500V AC, 1 min
Protection Type	High battery, low battery, over load, short circuit, over temperature, pole-confusion protection for storage battery
Operation Ambient Temperature	-10 ~ 50°C
Operation Altitude	<=4000m
Operation Ambient Humidity	0-90%, no condensing
Size (W x H x D)mm	470 x 430 x 300
Weight (KG)	24.5