

PowerMax+

INSTALLATION MANUAL 2000 Off-Grid



1108 Summit Avenue, Suite 8
Plano, TX 75074
866-WND-PWRD
www.acgreenenergy.com



CONTENTS

Parts List	3
Technical Specifications and Output Graphs	4
Installation Specifications (Guyed Tower)	5
Installation Specifications (Tapered Tower)	11
Connection of the Charger Controller	12
Connection of Storage Batteries	13
Electric Wiring	13
Maintenance	15
FAQ (Frequently Asked Questions)	15
PowerMax+ PM2048 Hybrid Charge Controller	17

Parts List

*Please inspect all packaging crates; contact your PowerMax+ reseller if there is any damage or missing parts.

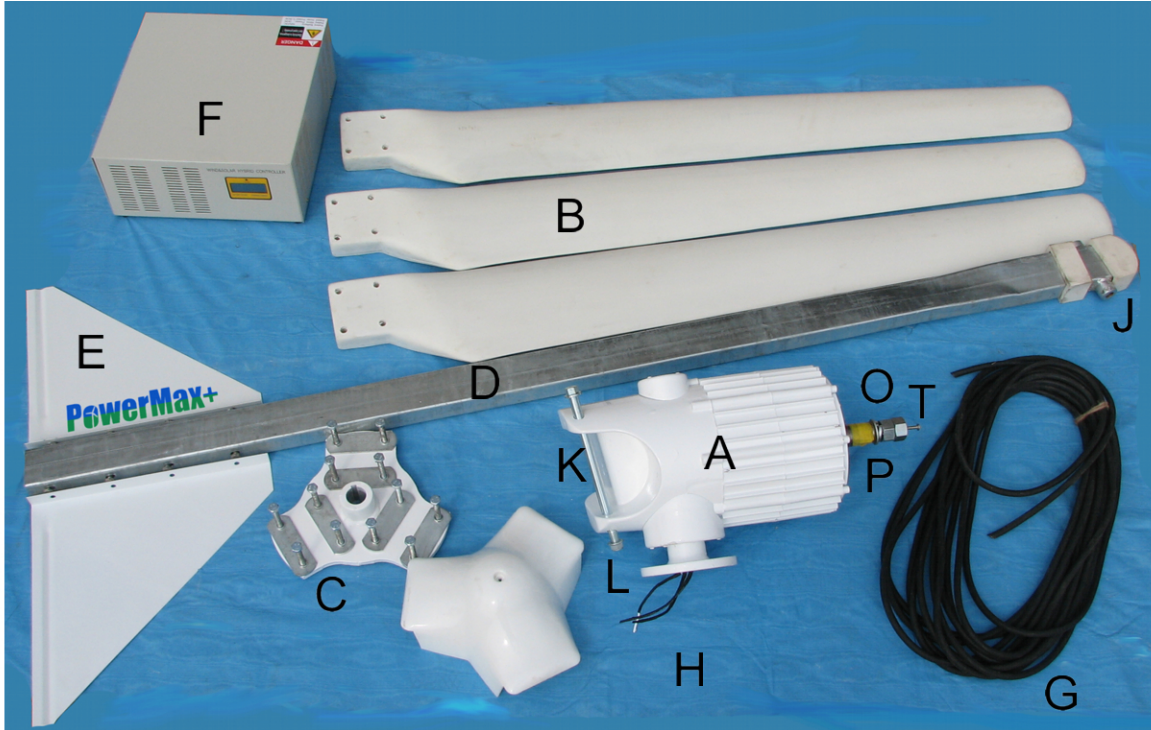

A	Generator
B	3 blades
C	hub
D	tail
E	(2) tail fins
F	charge controller/load dump
G	60' 12-guage cable
H	plastic nose cone
I	(6) blade press plates
J	(2) rubber tail furling cushions
K	(1) 290mm long x 20mm hex head tail bolt
L	(1) 20mm hex head tail bolt
M	(12) 76mm long x 16mm hex head bolts
N	(12) lock washers
O	(2) 36mm hex nut
P	(1) lock washer
Q	(4) 105mm long x 14mm hex head bolts
R	(4) 14 mm hex nuts
S	(4) lock washers
T	(1) 60mm nose cone bolt
	Installation Manual

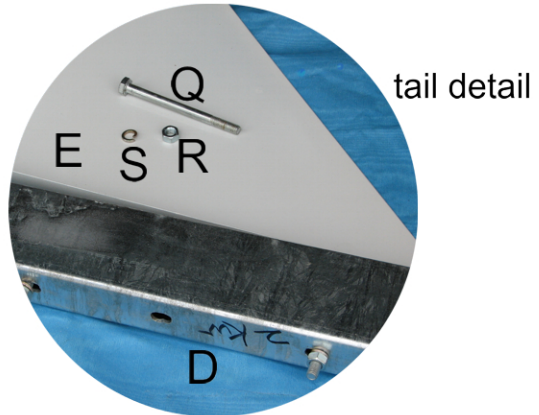
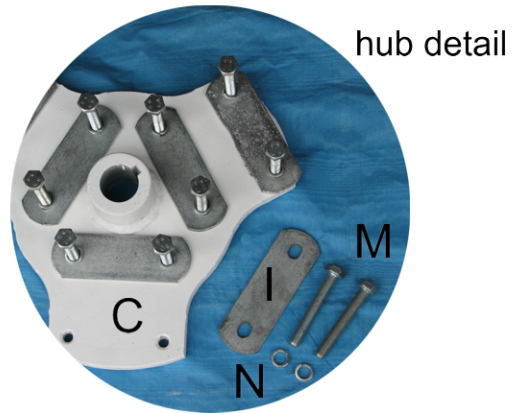

Technical Specifications	
Blade Number	3
Startup Speed	4.5
Cut-in Speed	5.6
Rated Speed	20
Survival Wind Speed (mph)	78
Rated Voltage (VDC)	48
Rated Power (W)	2000
Peak Power (W)	2500
Rotor Diameter (ft)	10.5

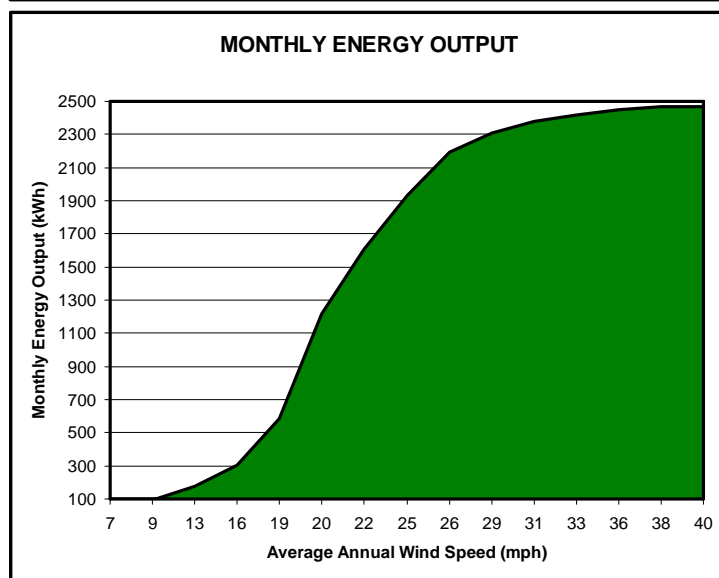
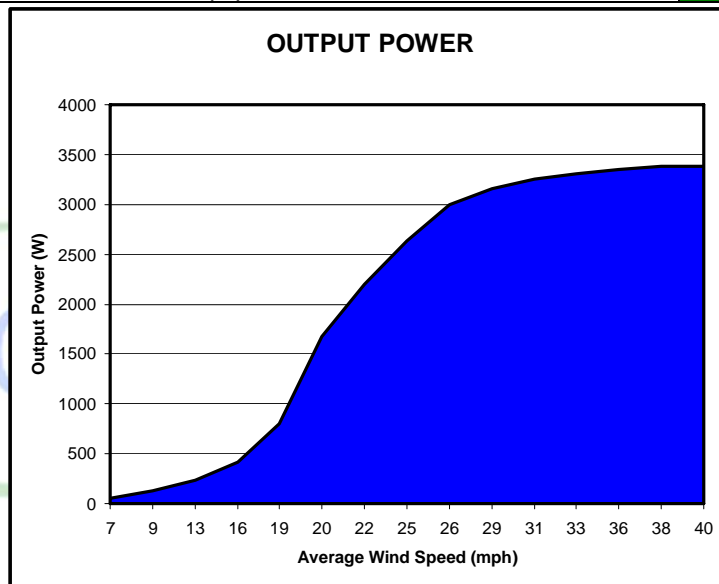

Installation of a Guyed Tower

Step 1: Choosing Your Installation Site

Your PowerMax+ wind turbine should be erected as high and as far away from obstacles, such as buildings and trees, in order to reach the best wind possible. Obstacles create wind turbulence that can lessen the turbine efficiency and could even lead to generator damage. Soil quality should be taken into consideration. Areas with loose sand, uneven soil, water erosion or weather-influenced (easily flooded) should NOT be chosen for wind turbine installation. When selecting your tower location, it is also necessary to consider the distance between the generator and pile. Shorter distances require less cable and help minimize energy waste during the power transmission. When circumstances call for longer distances, heavier gauge wire is recommended.

Please refer to the following chart for *minimum* pillar and base recommendations:

TABLE 1

Model: 2000	Metric (meters)	English (feet)
Radius	4	13
Size of Central Base: L x W x D	.6 x .6 x .5	2 x 2 x 1.6
Size of each Side Base: L x W x D	.5 x .5 x .4	1.6 x 1.6 x 1.3

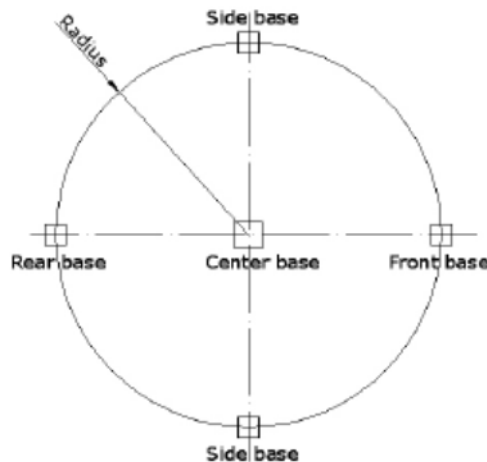

Figure 1: layout of concrete base

Special attention should be paid to the following when laying out each base and anchor:

- The two anchors should line up with the pin holes on the hinge. If a line is drawn between the two anchors, the line should go through the center of the two pin holes.
- All the anchors should be on the same horizontal level with the tower base so that the pulling force from the two side anchors will be equal. Otherwise, the tower may bend or breakdown when you fasten the rear cable.

Disclaimer: Since the soil conditions vary from location to location, please consult with a soil analysis company or structural engineering firm in your area about the structural data in this manual. Please understand that A&C will not responsible for the structural failure caused by the tower base problems.

Step 2: Preparing the Concrete Bases for the Tower and the Anchors

1. Dig the holes to follow the pattern as shown in Fig.1. Please refer to the Table 1 for the dimensions of the holes.
2. Please choose cement C25. The 4 anchors should be installed with the bolts being plugged in the cement. The 4 anchors should be oriented in the way which is described in step 1. Put the bolts in the cement before it cures.

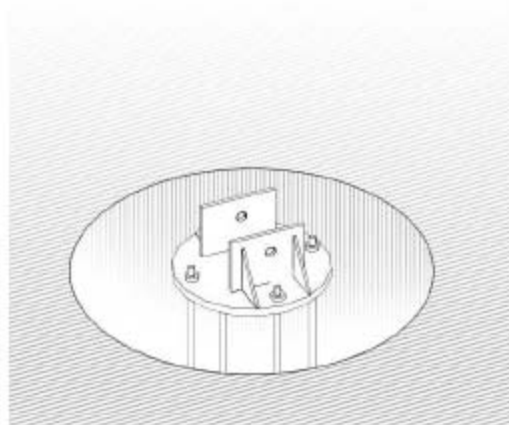

Graph 2

3. The anchors should have a 60° to 80° angle to the horizontal plane. Make sure the anchors are evenly distributed along the circle and they all have the same distance to the center base. All the connection rings should be on the same level.

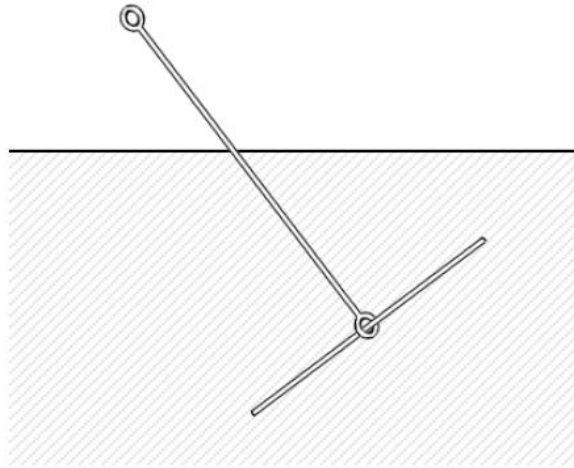

Graph 3



Step 3: Assembly the tower and wind turbine

1. Insert the main section of tower into the base, then slide the pin through the tower and base, lock it with the split pin. (As shown in the graph 4)

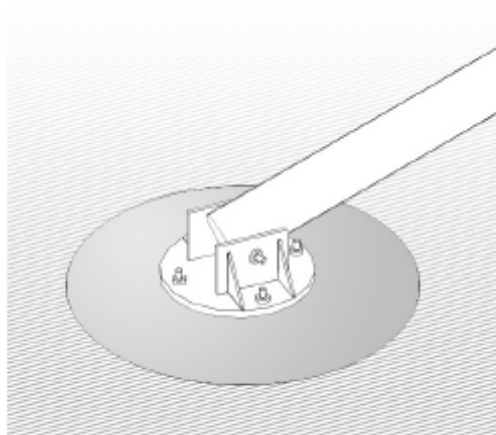

Graph 4

2. Lay out the individual pole pieces in order of eventual assembly.
3. Insert the generator cables through the tower pieces, and pull the cables out of the main section of the tower. It is easier to feed the cables through each tower section before assembly, instead of trying to feed the cables through the entire length of the assembled tower.
4. Using the nuts, bolts and washers provided, connect each section of tower one by one, and place the tower on a supporting stand after assembly. This supporting stand keeps the top of the tower off the ground so that you can more easily mount the generator later.
5. Connect the cables to the generator. Pull the cable slack through the base of the tower.
6. While one person positions the generator on the top of the tower, the second person needs to bolt the running flange and tower flange together. Make sure the shaft faces upward in order to install the blades/hub assembly.
7. Position the stand so that the generator is elevated about 5'-6' off the ground, so that the tail can be connected with enough ground clearance.
8. Assemble the tail and fins. Attach the tail to the generator so that the tail is pointing toward the ground, otherwise the weight of the tail will cause the generator to flip over, resulting in possible personal injury or property damage.
9. Arrange the three blades on the hub, then put on the press pad. Slide the screws into the holes and put on the nuts. Before tightening the nuts, please make sure the 3 blades are evenly installed by measuring the distance between the blade tips.
(refer to Graph 5 on the following page)

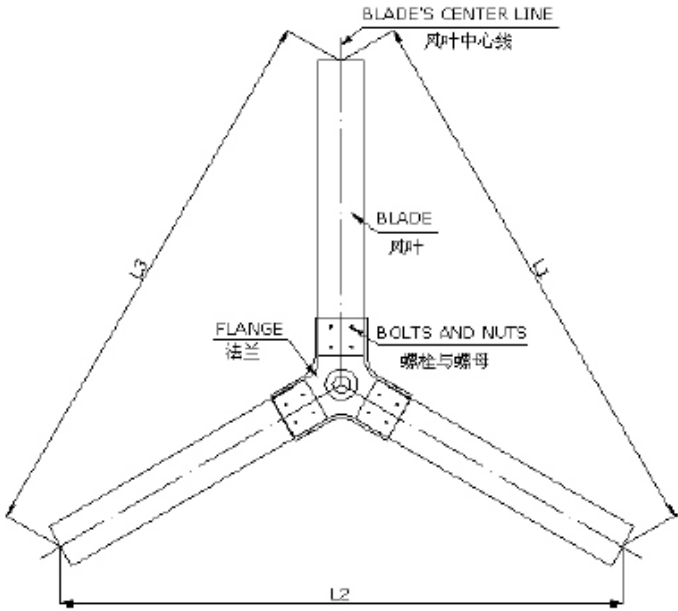

Graph 5

L1=L2=L3 (Tolerance +/- 5mm or 1/8")

Note: It is recommended to use a torque wrench to tighten the blade nuts. This ensures an even amount of pressure across the blade and will prevent possible warping or rotor imbalance. Set the torque based on the followings table:

System	2KW
Torque	30NM+/-1

Disclaimer: Please follow the above table for the torque settings. Make sure the wrench is calibrated properly. A&C will not be responsible for any damages caused by improper tightening.

10. Tighten the screws following the order indicated in graph 6.

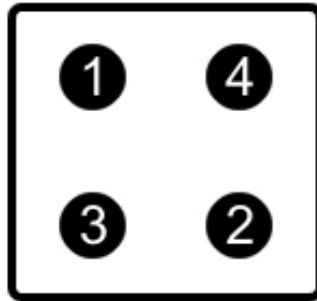

Graph 6

11. Bolt the hub and blades to the shaft, then install the nose cone.

PLEASE REFER TO THE MAINTANENCE SECTION OF THIS MANUAL TO GET TIPS ON LUBRICATING AND OILING GENERATOR PARTS FOR PROLONGED TURBINE EFFICIENCY.

Step 4: Preparation before erecting the tower

1. Connect the 4 guy wires to your tower. Connect the SIDE guy wires to the SIDE bases.
2. Connect the FRONT guy wire to a winch, tractor or truck.
2. Pass the other end of the wire cable or bracing cord over a heavy ladder or pulley brace, which will serve as a Jin-pole.

Step 5: Erecting the tower

1. Drive the winch or tractor slowly so the tower will rise gradually, stopping every 15° to check the tension of the guy-wires on both sides. If you find the tension is not balanced, either too loose or too tight, please lower the tower slowly and adjust the length of the guy-wires accordingly. Once balanced SIDE guy wire tension is established, keep pulling until the tower stands upright. Separate the cord and fix the FRONT guy-wire to the front anchor, then the BACK guy wire to its anchor. Be sure all four guy wires have even tension.

Model	Code in the graph 8	1000W	2000W	3000W	5000W	10KW	20KW
Ground depth(m)	(D1)	1.2	1.5	1.5	1.6	2.0	3.0
Ground diameter(m)	(C1)	1.0	1.0	1.2	1.5	1.8	2.5
Burial depth of cotter bolt (m)	(D2)	0.8	1.2	1.2	1.2	1.6	2.0
Layout diameter of cotter bolt (mm)	(C2)	450	600	600	700	1000	1200
Specification of cotter bolt	(T)	M18	M18	M20	M24	M24	M30
Quantity of cotter bolt	(N)	12	12	12	12	16	16

Table 2

Step 3: Assembly of the tower and the generator

Please refer to the installation specification of guyed tower (step 3)

Step 4: Lifting the tower

While installing the tapered tower a professionally operated crane is needed. Non-working people and/or casual onlookers should be far away from the site when hoisting.

Step 5: Connect the cable to the upper end of the pole and lift gradually.

Step 6: When the tower is at the upright position, align the holes on the tower flange to the holes on the base flange and tighten them.

Connection of the Charger Controller

IMPORTANT: Refer to Appendix One

To prevent bodily injury or property damage, please follow these instructions precisely. With personal safety as a primary focus in design, this charge controller has been engineered to function properly and efficiently.

There are 3 leads coming from the wind generator and they are to be connected to the charge controller. The connectors to be connected should be marked as wind generator inputs.

Please make sure that generator is not generating power when you connect the charge controller and make sure that all the three wires are connected. Not doing so may cause the system damage or personal injury.

Connection of the Batteries

Note: All batteries should remain inside dry buildings with a constant temperature.

1. Arrange the batteries, controller and inverter in order of connection prior to actually connecting the individual components.
2. Connect the batteries in **series**.
3. Lubricate the connectors for better conductance. Install a fuse on the positive terminal of the battery. The distance between the batteries and the controller should not exceed 3m.
4. Suggested battery capacity for various models (as shown in table 3)

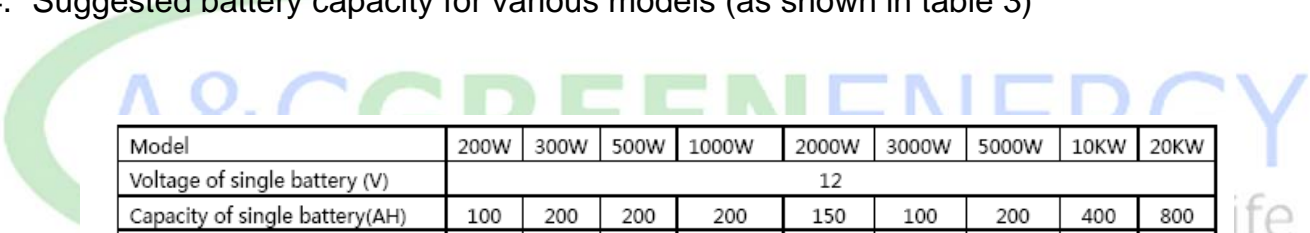

Model	200W	300W	500W	1000W	2000W	3000W	5000W	10KW	20KW
Voltage of single battery (V)	12								
Capacity of single battery(AH)	100	200	200	200	150	100	200	400	800
Quantity in series	2	2	2	4	10	20	20	20	30

Table 3

5. Charge Voltages for batteries (as shown in table 4)

Battery voltage(V)	12	24	36	48	120	240	360
Float charge voltage (V)	15	30	45	60	150	300	450
Overvoltage (V)	15	30	45	60	150	300	450
Over charge resume voltage (V)	14	28	42	56	140	280	420
Undervoltage (V)	10.5	21	32	42	105	210	315
Under charge resume voltage (V)	12	24	36	48	120	240	360

Table 4

Electric Wiring

1. Off-grid electric wiring

To ensure safety and easy maintenance, please install the switch and fuse according to the diagram. Check for output voltage consistency of the generator, battery and input of inverter.

A mistake in wire connection could destroy the generator, batteries and inverter.

Please refer to appendix 2 for controller specification

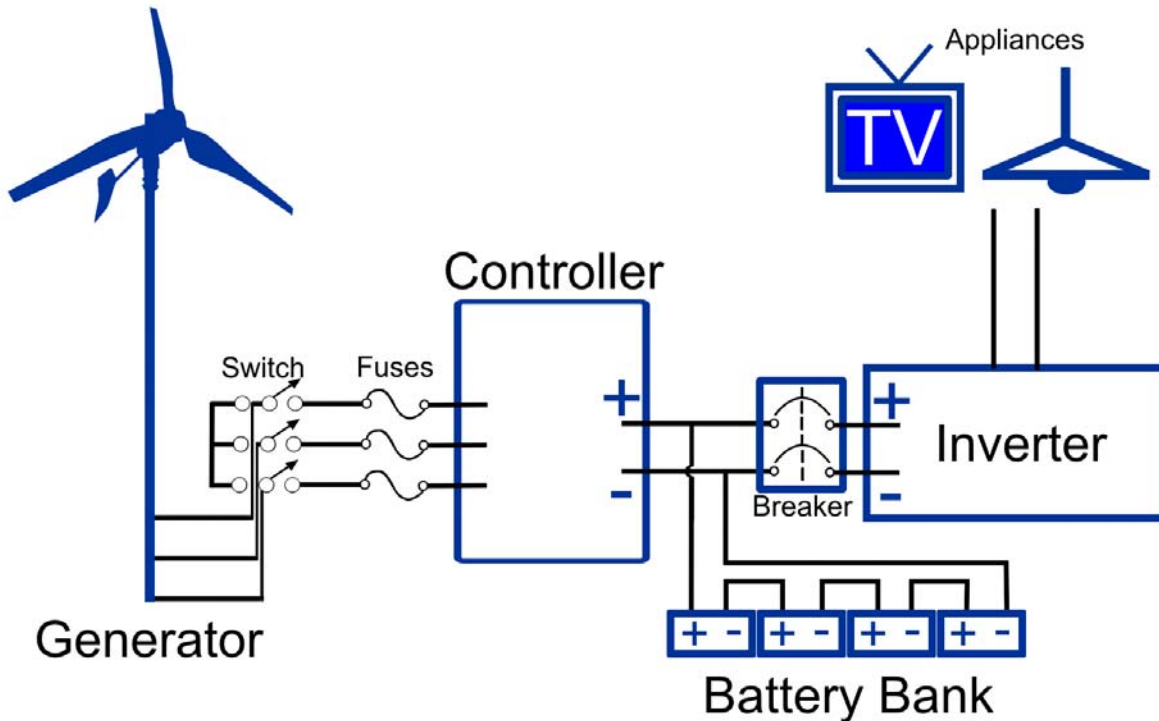

Typical Off-Grid System

Maintenance

The wind generators may operate under harsh environments and extreme weather situations. Regular inspection and maintenance are necessary to keep the system operating efficiently.

* Using heavy grease, coat the tail connection furling rod. Failed furling can cause your generator to overheat and cause permanent damage. Also grease the generator shaft. Using oil, coat the outside blade mounting brackets. These steps are crucial in preventing possible corrosion of these parts and also could cause generator damage.

3-month maintenance schedule:

1. Check tensions of the guy-wire. Make sure the wires are evenly tightened. The wire should be neither too tight nor too loose. This check has to be done at the installation time and again one week later, to correct any stretching or climactic adjustment.
2. Check electrical wires for connectivity and make sure they are not damaged or corroded.
3. Maintain the batteries as per the battery owner's manual.
4. If at all possible with proper warning before a big storm, lay down the tower to avoid unnecessary loss.

FAQs and Trouble Shooting

- Why the system may not have output power after the inverter is connected?
 - Check the diversion load and the charge controller. The charge controller has voltage and current indicators. So if there is not enough power generated, the system will not output energy. Also check the battery voltage, since if the battery voltage is low, it will not output energy either. But in case the energy is enough and there is still not output, please check the electrical wire connections between batteries and inverter and make sure there are no open wire shorts.

- Why the batteries cannot be charged?
 - Check whether or not the rotor is rotating. The generator has no output at too high or too low wind speed. If the rotor works normally, disconnect the generator's wire from the charge controller and check the generator output with a multi-meter. If the generator output is normal, please check if the batteries are ok, otherwise check the generator wiring.
- Why the rotor may not rotate at a normal wind speed?
 - Check if the generator output is short circuited. The generator won't rotate when the generator is short circuited. Be sure to disconnect the batteries from the charge controller when you perform this checking.
- How to lay down the generator?
 - 1. Disconnect the generator from the controller. Disconnect the generator output to prevent the generator from running.
 - 2. Perform the reverse steps of the installation to lay down the generator.
- Can I increase the battery capacity to increase the running time for electrical appliances?
 - Increasing the battery capacity may cause the batteries to be under charged and shorten the battery life.
- How long is the generator's lifespan
 - Under normal care and maintenance, your generator will efficiently produce energy for 15 years.

If you have further questions, please contact your authorized PowerMax+ agent.

- Images and photographs may vary.
- This manual may be modified without notice.
- Turbine warranty is 2 years.
- Charge controller and inverter warranties are each 1 year.

PowerMax+ PM2048 Hybrid Charge Controller

1. Security

IMPORTANT: To prevent bodily injury or property damage, please follow these instructions precisely. With personal safety as a primary focus in design, this charge controller has been engineered to function properly and efficiently.

1. Professional installation and guidance is always recommended. Otherwise, please contact your authorized PowerMax+ agent before installation.
2. Keep the charge controller dry. Do not clean with a wet or damp cloth. This is an electric device and cannot get wet at all. Prevent any spills on or near the controller.
3. Keep all children and any person with limited understanding and/or decreased mental capacity away from the controller.
4. Keep the controller away from direct sunlight or any other heat source.
5. Please check the rated voltages of your wind turbine, solar panel and battery before connection. Their rated voltages all should be the same.
6. Pay close attention to the connection of your wind turbine, solar panels and batteries to make sure positive goes to positive and negative goes to negative.
7. Smaller gauge wires should not be used with higher current equipment.
8. Ensure that all component connections are tight and secure.
9. **DO NOT TOUCH** any bare parts on the controller. The high voltage can cause lethal shock.

2. General Description

Your PowerMax+ wind/solar hybrid controller is designed to control the wind power charging battery under constant voltage. In addition, it includes a solar charging control, which makes it good for wind/solar hybrid application.

At the right side of the controller, there is a manual brake switch. If the switch is turned to the 'brake' position, the wind turbine will be manually stopped.

3. Connection

1. Turn the 'manual brake' to the 'BRAKE' position, and then connect the output of the wind generator to the 'WIND INPUT' terminals using 10mm² cable.
2. If applicable, connect the output of your solar panel to the 'SOLAR INPUT' terminals on the PowerMax+ controller. Positive to positive, negative to negative.
3. Using 10mm² cables, connect the battery's positive pole to the positive (+) 'battery' terminal on the controller and connect the battery's negative pole to the negative (-) 'battery' terminal on the controller. The length of the cables should be no longer than three (3) feet. Tighten the nut on each 'battery' terminal by hand. Do not over tighten.
4. Turn the 'manual brake' to the 'RUN' position.

MODEL	PM20-48
Maximum Wind Input Power	2kW
Maximum PV Input Power	.6kW
Rated Battery Voltage	48V
Floating Charge Voltage	56V
Control Mode	charge under limited current and voltage with PWM mode
Display Mode	LCD
Displayed Parameter	Battery Voltage, Charge Current
Protection Type	Pole-confusion protection, Automatic dump-load function
Size (W x H x D)mm	470x230x410
Weight (KG)	12

